

№ 1, 2 Ребровый клин

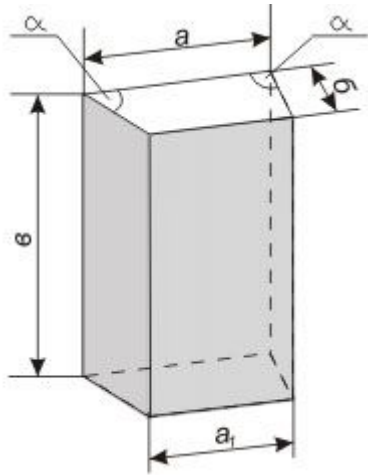

Номер изделия	Размеры, мм			
	а	а ₁	б	в
1	140	120	65	250
2	140	125	80	250
2а	80	68	120	300
2б	80	68	160	300

№ 3, 4 Торцовый клин

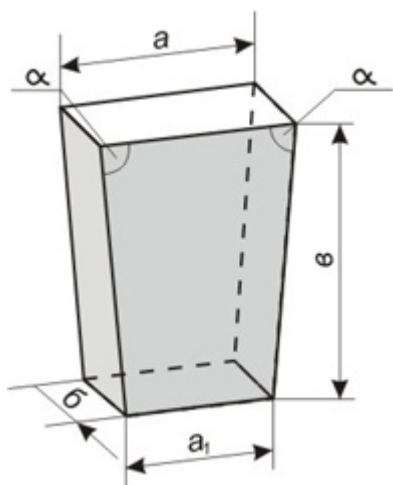

Номер изделий	Размеры, мм			
	a	a ₁	b	в
3	140	135	65	250
4	140	135	80	250

№ 6-21,21a Трапецидальный клин

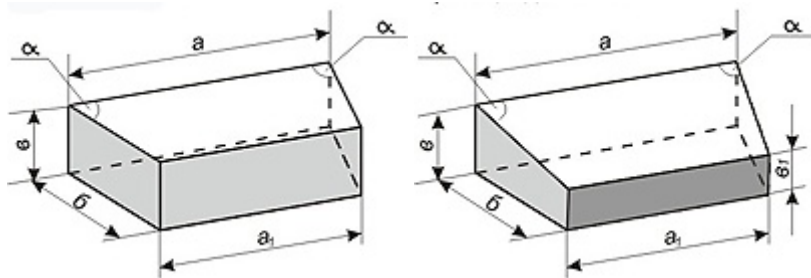

Номер изделий	Размеры, мм				
	a	a ₁	b	B	B ₁
6	250	239	80	80	-
7	210	181	100	80	-
8	230	209	100	80	-
9	250	236	100	80	-
10	210	176	120	80	-
11	230	206	120	80	-
12	230	212	120	80	-
13	250	235	120	80	-
14	210	178	150	80	-
14a	225	205	150	80	-
15	230	205	150	80	-
15a	245	210	150	80	-
16	250	232	150	80	-
16a	250	228	150	80	-
18	220	192	200	80	-
19	240	216	200	80	-
20	230	200	250	80	-
21	250	221	250	80	-
21a	240	213	200	80	60

№ 22-36 Трапецидальный клин с соотношением $v/v_1 \leq 1$

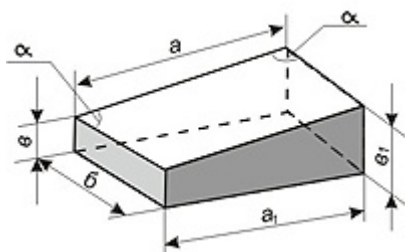

Номера изделий	Размеры, мм				
	a	a ₁	б	в	в ₁
22	230	205	150	40	40
23	230	205	150	40	50
24	230	205	150	50	60
25	230	205	150	60	70
26	230	205	150	70	80
27	220	192	200	40	40
28	220	192	200	40	50
29	220	192	200	50	60
30	220	192	200	60	70
31	220	192	200	70	80
32	250	221	250	40	40
33	250	221	250	40	50
34	250	221	250	50	60
35	250	221	250	60	70
36	250	221	250	70	80

№ 37-39 Прямоугольный кирпич

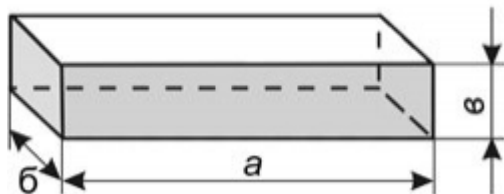

Номера изделий	Размеры, мм		
	а	б	в
37	250	100	80
38	300	120	80
39	300	150	80